

DATASHEET

Mica

A5645H • gigaNOVA®

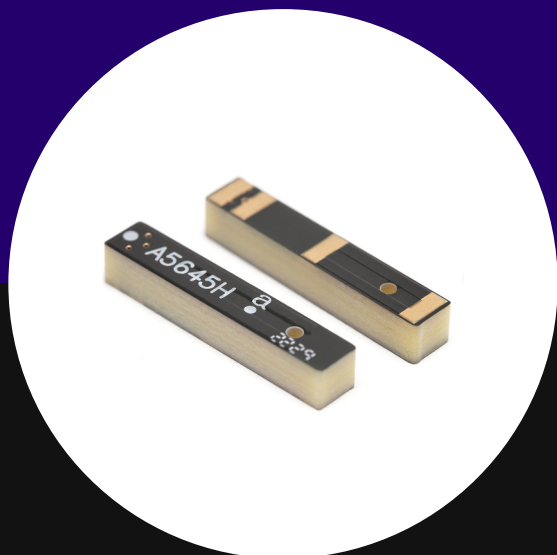

Features

- Designed for 2.4GHz applications: Bluetooth®, Wi-Fi® (802.11a/b/g/n), ZigBee®, etc.
- Designed for use with the ground plane extended beneath the antenna
- Easy to integrate
- Low profile design
- High efficiency
- Intended for SMD mounting
- Supplied in tape and reel

Note: This product is compatible with Bluetooth® technology but does not incorporate Bluetooth® technology

1. Description

Mica is intended for use with all 2.4 GHz applications. The antenna uses a ground plane in order to radiate efficiently.

2. Applications

- Wearables
- Notebooks
- PC-cards
- Sensors

3. General data

Frequency	2.4-2.5GHz
Polarization	Linear
Operating temperature	-40°C to 140°C
Environmental condition test	ISO16750-4 5.1.1.1/5.1.2.1/5.3.2
Impedance with matching	50 Ω
Weight	<0.5g
Antenna type	SMD
Dimensions	19.7 x 3.6 x 3.3 (mm)

4. Part number

A5645H



5. RF characteristics

Frequency	2.4-2.5GHz
Peak gain	1.8dBi
Average gain (Linear)	-1.9dBi
Average efficiency	65%
Maximum return loss	-11dB
Maximum VSWR	1.8:1

All data measured on Antenna's evaluation PCB Part No. A5645H-EVB-1

6. RF performance

6.1. Return loss

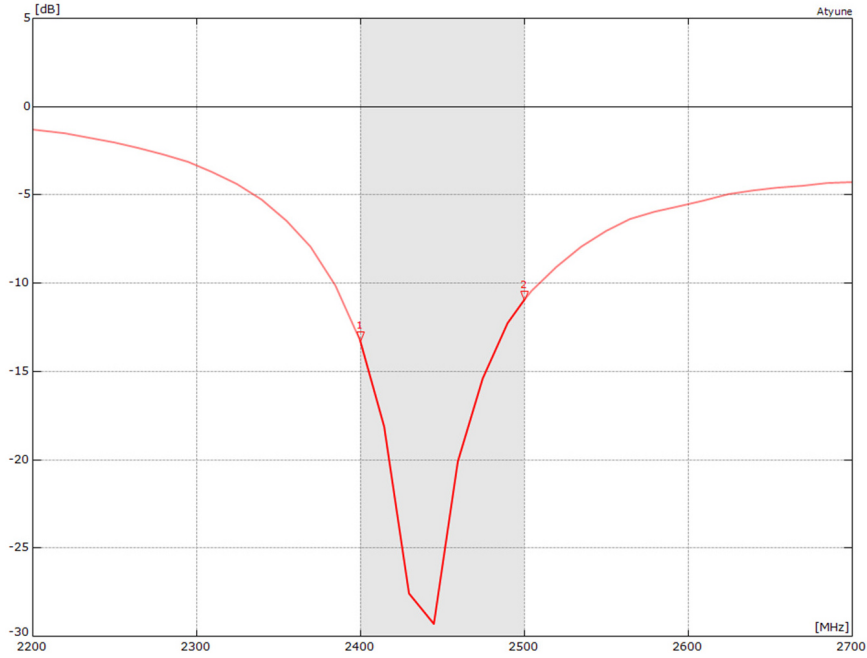

6.2. VSWR

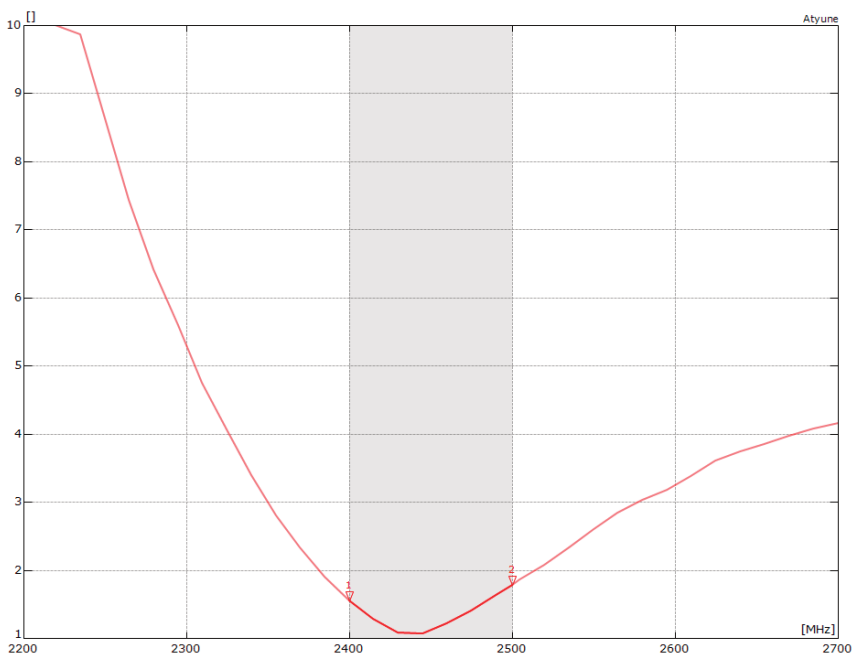

6.3. Efficiency

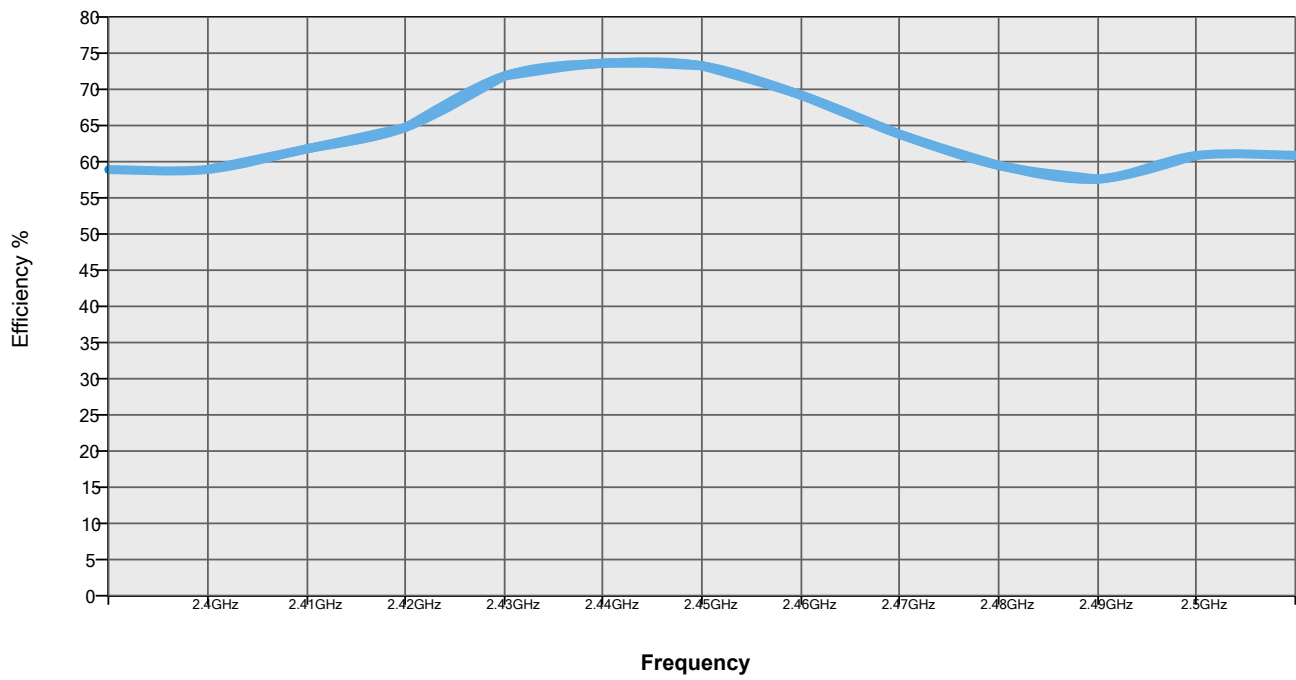

All data measured on Antenova's evaluation PCB Part No. A5645H-EVB-1

7.3 Antenna pattern

7.3.1. 2400 MHz – 2500 MHz

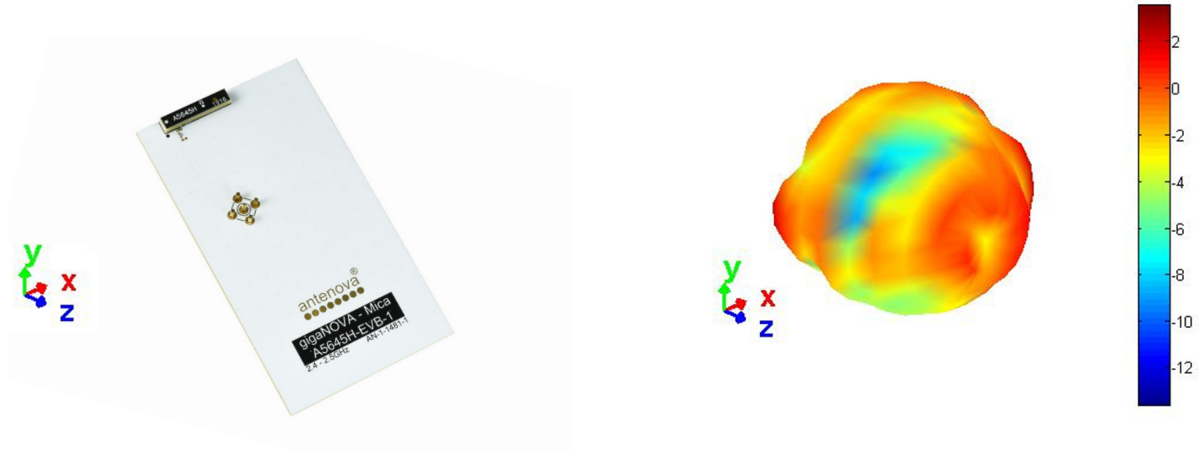

XY

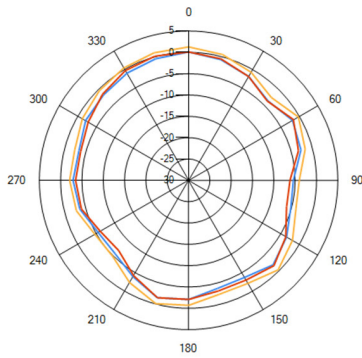

XZ

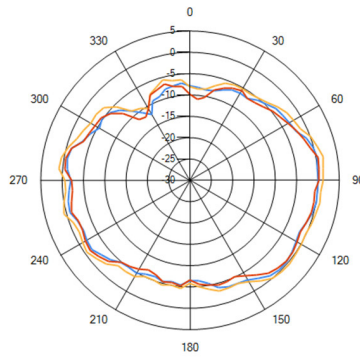

YZ

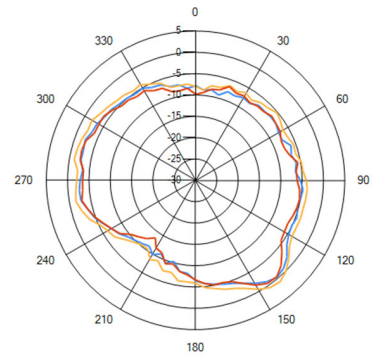

— 2.4GHz — 2.45GHz — 2.5GHz

7. Antenna dimensions

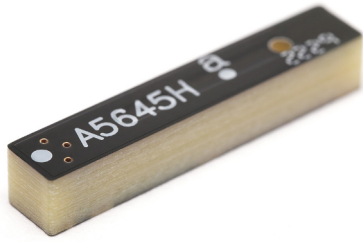

Top view

All dimensions in (mm)

L	W	H
Length	Width	Height
19.7 ±0.1	3.6 ±0.1	3.3 ±0.2

All dimensions in (mm)

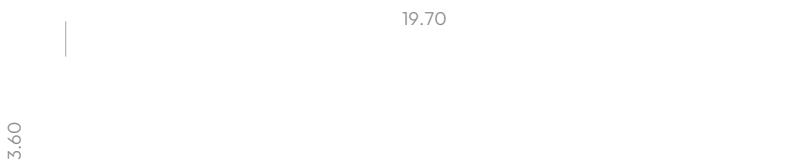

Bottom view

8. Schematic symbol and pin definition

The circuit symbol for the antenna is shown below. The antenna has 4 pins and with pin1 and pin2 functional. All other pins are for mechanical strength.

Pin	Description
2	Feed (Transceiver port)
1, 3, 4	Return/GND

Mica A5645H

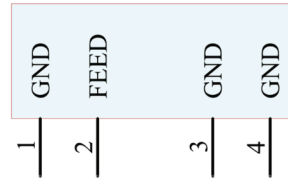

9. Host PCB footprint

The recommended host PCB footprint is below.

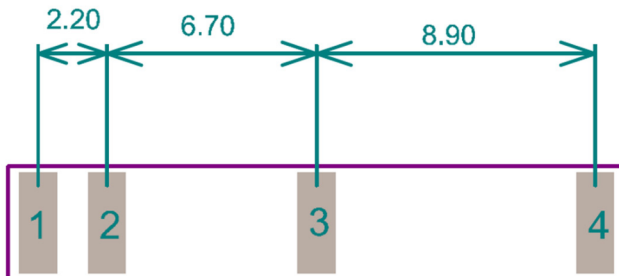

Pads 1-4 = 3.2 x 1.2 (mm)

10. Electrical interface

10.1. Transmission line

All transmission lines should be designed to have a characteristic impedance of 50Ω.

- The length of each transmission lines should be kept to a minimum
- All other parts of the RF system like transceivers, power amplifiers, etc, should also be designed to have a 50 Ω impedance

A co-planar transmission line can be designed using an online transmission line calculator tool, such as:

<https://blog.antenova.com/rf-transmission-line-calculator>

The PCB thickness, copper thickness and substrate dielectric constant are entered, then the tool calculates the transmission line width and gaps on either side of the track to give a 50 Ω impedance.

10.2. Matching circuit

The antenna requires a matching circuit that must be optimized for each product. The matching circuit will require up to three components and the following circuit should be designed into the host PCB. Not all components may be required but should be included as a precaution. The matching network should be placed close to the antenna feed to ensure it is optionally effective in tuning the antenna.

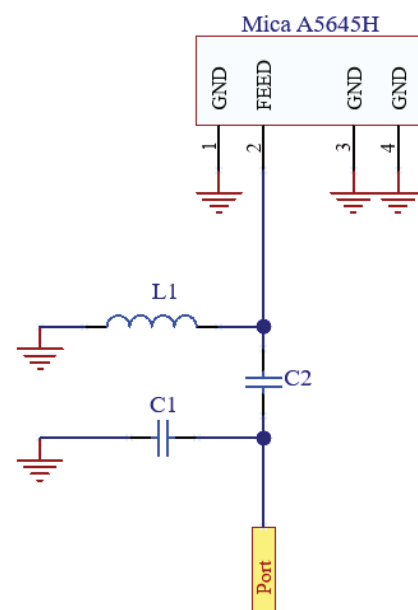

11. Antenna integration guide

We recommend the following during the design phase to maximise antenna performance and minimize noise:

- Minimum 4 layer PCB
- Route signals and power internally where possible
- Flood all layers with ground
- Knit ground on all layers together with plenty of vias

Follow placement guidance carefully, in addition Antenova provide technical support to help you through all stages of your design. Register for an account on <https://ask.antenova.com/> to access technical support.

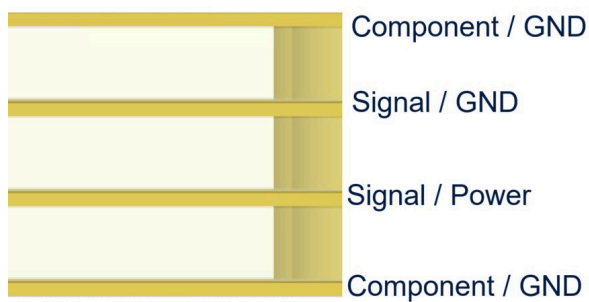

11.1. Antenna placement

The best position of the antenna is to be placed at the edge of the board as shown below.

The Antenova placement tool can be used to advise on antenna placement, see: :

<https://blog.antenova.com/intelligent-antenna-selection-and-placement-tool-antenova>

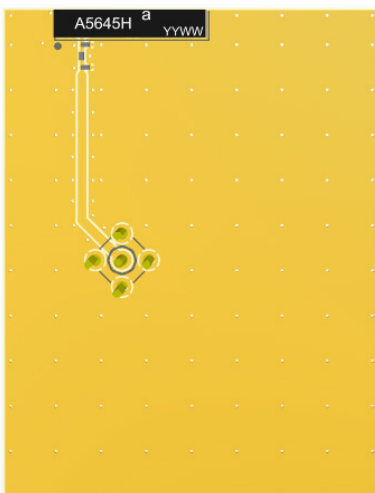

11.2. Host PCB layout

Antenova strongly recommends placing the antenna at the edge of the board. Maximum antenna performance is achieved by placing the antenna towards one of the corners of the PCB and with the feed point of the antenna as close to same corner of the PCB as possible.

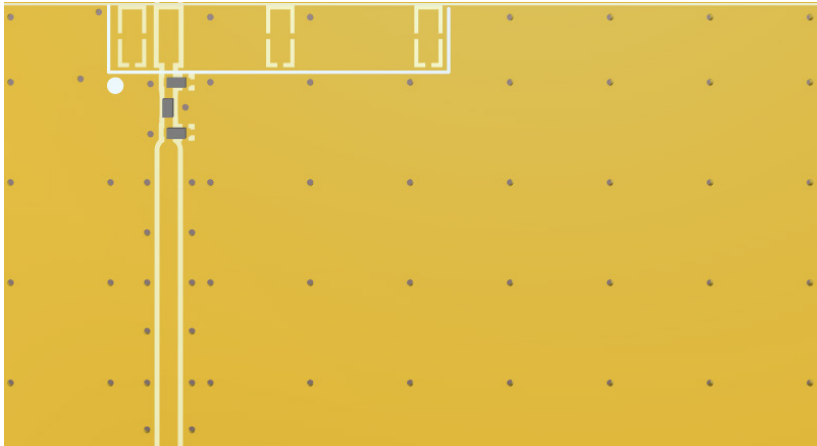

12. Reference board

A reference board is used for evaluating the antenna A5645H and it includes a SMA female connector. (Part number: A5645H-EVB-1)

To order a reference board [please see antenova.com](http://www.antenova.com)

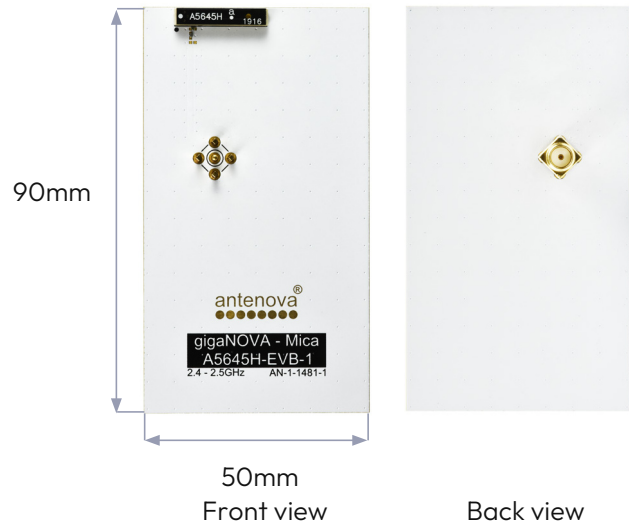

12.1. Reference board matching circuit

Designator	Type	Value	Description
L1	Inductor	5.6nH	Murata LQG15HN series
C2	Capacitor	1.5pF	MurataGJM15 series
C1	Capacitor	Not fitted	Not fitted

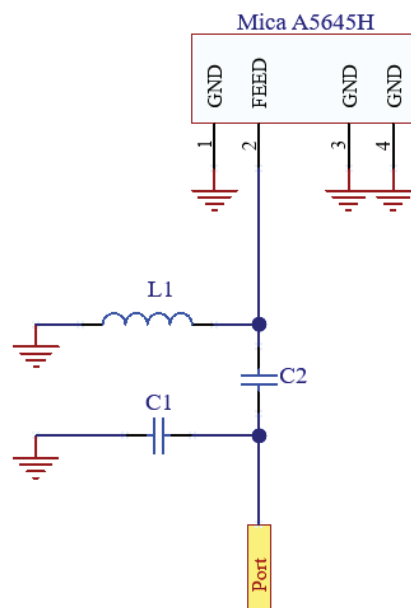

13. Soldering

This antenna is suitable for lead free soldering. The reflow profile should be adjusted to suit the device, oven and solder paste, while observing the following conditions:

- For leaded soldering, the maximum temperature should not exceed 240 °C.
- For lead free soldering, a maximum temperature of 255 °C for no more than 20 seconds is permitted.
- The antenna should not be exposed to temperatures exceeding 120 °C more than 3 times during the soldering process.

14. Hazardous material regulation conformance

The antenna has been tested to conform to RoHS and REACH requirements. A certificate of conformance is available from Antenova's website.

15. Packaging

15.1. Optimal storage conditions

Temperature	-10°C to 40°C
Humidity	Less than 75% RH
Shelf life	24 Months
Storage place	Away from corrosive gas and direct sunlight
Packaging	Reels should be stored in unopened sealed manufacturer's plastic packaging.
MSL level	1

Note: Storage of open reels of antennas is not recommended due to possible oxidization of pads on antennas. If short term storage is necessary, then it is highly recommended that the bag containing the antenna reel is re-sealed and stored in conditions as described in the tabel above.

The shelf life of the antenna is 2 years provided the factory seal on the package has not been broken.

15.2. Tape characteristics

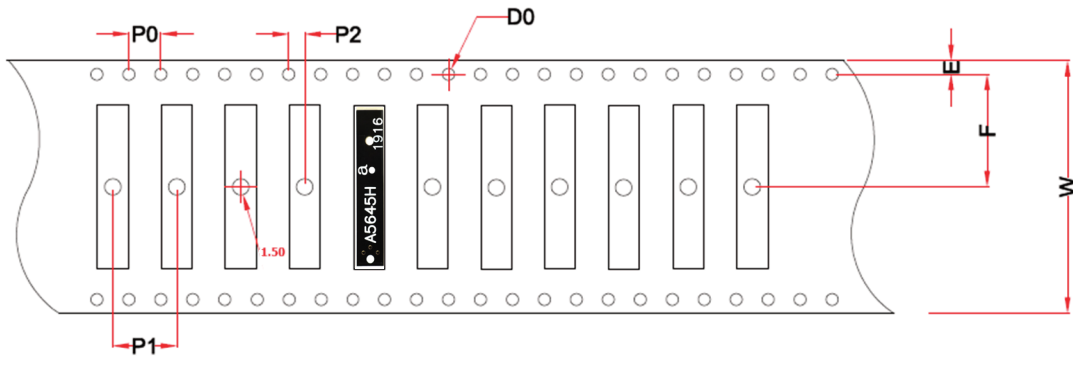

P0	P1	P2	D0
4.00 ± 0.1	8.00 ± 0.1	2.00 ± 0.1	1.50 ± 0.1

E	F	W
1.75 ± 0.1	14.20 ± 0.1	32.00 ± 0.3

All dimensions in (mm)

Quantity	Leading space	Trailing space
2000 pcs / reel	50 blank antenna holders	37 blank antenna holders

15.3. Reel dimensions

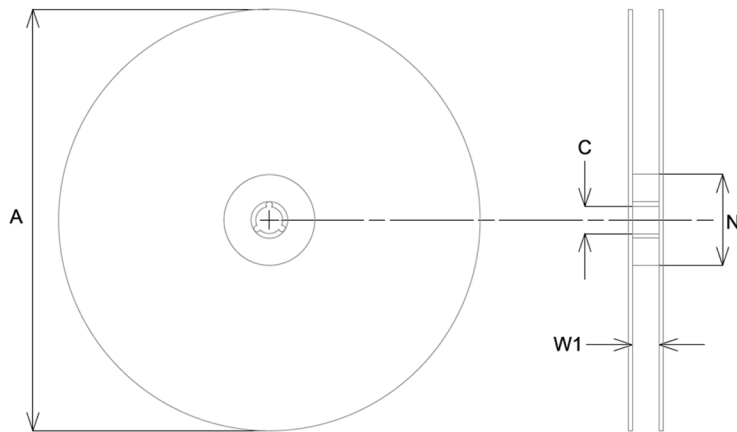

A	C	N	W1
330.0 ± 2.0	13.0 ± 0.5	100.0 ± 0.5	35

All dimensions in (mm)

15.4. Box dimensions

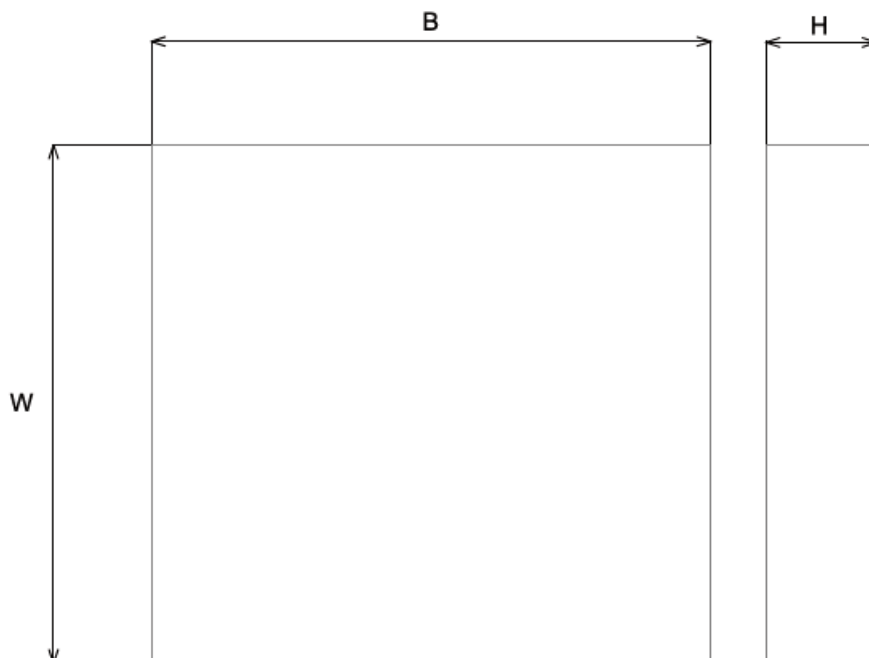

Width (W)	Breadth (B)	Height (H)
345mm	345mm	45mm

15.5. Bag properties

Reels are supplied in protective plastic packaging.

15.6. Reel label information



Quality statements

Antenova's products conform to REACH and RoHS legislation. For our statements regarding these and other quality standards, please see antenova.com.

Antenova reserves all rights to the contents of this document. Antenova gives no warranties based solely on the accuracy or completeness of the contents of this document and reserves the right to make changes to the specifications of the products described herein at any time and without notice.



Datasheet version

4.05 released 20th March 2026

Antenna design, integration and test resources

Product designers – the details contained in this datasheet will help you to complete your embedded antenna design. Please follow our technical advice carefully to obtain optimum antenna performance.

We aim to support our customers to create high performance wireless products. You will find a wealth of design resources, calculators and case studies to aid your design on our website.

Antenova's design laboratories are equipped with the latest antenna design tools and test chambers. We provide antenna design, test and technical integration services to help you complete your design and obtain the required certifications.

If you cannot find the antenna you require in our product range, please contact us to discuss creating a custom antenna to meet your exact requirements.

Share knowledge with RF Experts around the world

ask.antenova is a global forum for designers and engineers working with wireless technology

[Visit Ask.Antenova](#)

Visit antenova.com

Order antenna samples and evaluation boards, and read our antenna resources

Visit antenova.com

Request a volume quotation for antennas:

sales@antenova.com

+ 44 (0) 23 9400 1023

Global headquarters

Antenova Ltd, 7 The Briars,
Waterberry Drive, Waterlooville,
Hampshire, PO7 7YH